



British Steel, Skinningrove Gantries Collection Plan Bundled Sections using Chains

Loading:
Monday – Friday 0700-1900

POST CODE: TS13 4ET

PPE Requirements:



Additional Information:



Reporting/Arrival:



**ON ARRIVAL STOP AT
SECURITY GATE **IN PPE****



DRIVER RECEPTION / INDUCTION



**WEIGHBRIDGE
Weigh ON**

Loading/Securing:

Stand in **SAFE HAVEN** during loading



OPEN BOTH CURTAINS AND STRAP FROM THE GROUND

Max X 7



Max X 10



Recommended 6 pairs



LOADS MUST BE SECURED IN THE STRAPPING AREA – PLEASE HAVE ALL EQUIPMENT READY

SECURING INFORMATION ON REVERSE SIDE

LRG 0016 Bundled Sections using Chains

3.1 Product blocked against the headboard

- ✓ Loaded to the headboard - maximum gap 100 mm.
- ✓ Up to 28 tonnes on a standard trailer restrained using over-the-top chains as shown in Table 1.
- ✓ Restraints are placed close to dunnage.

Table 1: No. of over-the-top chains when loaded to trailer

Load weight	5 tonne headboard	10 tonne headboard
0-20 t	2	2
20-25 t	3	2
25-28 t	4	3

Valid for both 8 mm and 10 mm chains.

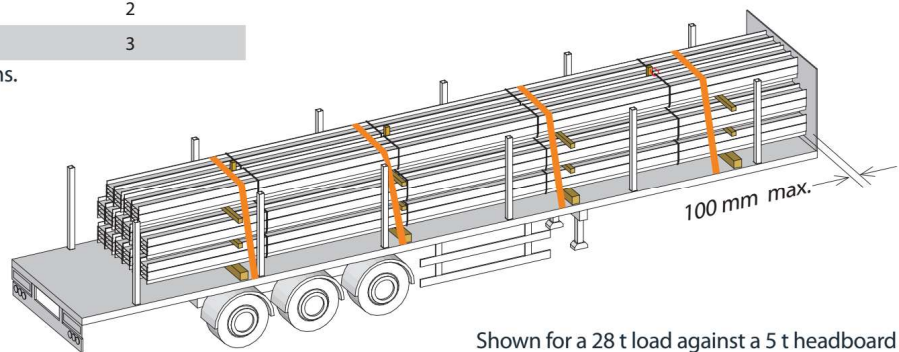

Shown for a 28 t load against a 5 t headboard

This Load Restraint Guideline is designed and tested to meet the forces for road and sea transport as stated in EN 12195-1:2010 and VDI 2700.



3.3 Product loaded away from the headboard

When more than 8 tonnes are loaded away from the headboard restrain using belly-wrap and over-the-top chains as shown in Tables 2 and 3.

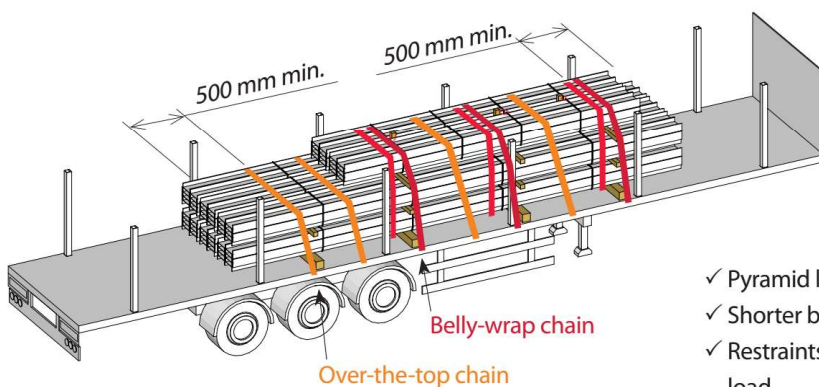

- ✓ Pyramid load build, maximum of 2 bundles on top tier.
- ✓ Shorter bundles placed on top tier.
- ✓ Restraints are a minimum of 500 mm from front and rear of load.
- ✓ Restraints are placed close to dunnage.

Table 2: 8 mm chains (LC 40 kN)

Load	Belly-wrap		Over-the-top	=	Total
0-15 t	3	+	1	=	4
15-20 t	3	+	2	=	5
20-25 t	3	+	3	=	6
25-28 t	3	+	4	=	7

Table 3: 10 mm chains (LC 63 kN)

Load	Belly-wrap		Over-the-top	=	Total
0-15 t	2	+	0	=	2
15-20 t	2	+	1	=	3
20-25 t	2	+	2	=	4
25-28 t	2	+	3	=	5